

# HA TBAS C

## HAMPTON Tap Range Hampton Tall Basin Mixer Without Waste Chrome



### Specification

<b>Product Type:</b>	Tall Basin Mixer
<b>Main Construction Material:</b>	Brass
<b>Mount Type:</b>	Deck
<b>Handle Type:</b>	Lever
<b>Connection Inlet:</b>	M10 X 15mm flexible connecting pipes
<b>Connection Outlet:</b>	Rectangular Flow Straightener
<b>Number of Tap Holes:</b>	1
<b>Valve/Cartridge Type:</b>	Manual
<b>Plumbing System Requirements:</b>	Suitable for high pressure systems
<b>Minimum Dynamic Pressure (bar):</b>	1 bar
<b>Maximum Dynamic Pressure (bar):</b>	5 bar
<b>Maximum Hot Water Temperature °C:</b>	65°C
<b>Maximum Static Pressure (bar):</b>	10 bar
<b>Flow Type:</b>	Single
<b>Isolation Included:</b>	No

### Features:

- Long life ceramic cartridge for added durability and ease of use
- Metal fixing nut for added durability
- Flexible tails included
- Minimum working pressure of 1.0 bar

### Product Certifications:



For more products, visit our website:  
<http://www.bristan.com>



### Dimensions (measurements in mm)

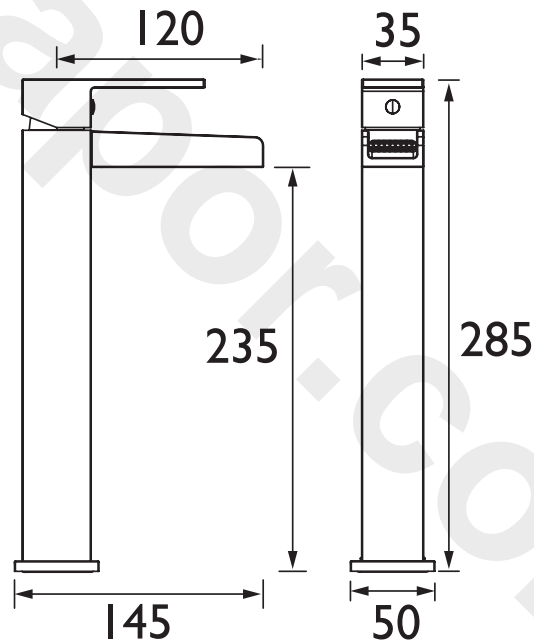

### Flow Rates (l/min)

System Pressure (bar)	1	2	3	5
HA TBAS C (mixed)	2.6	3.7	4.5	5.8

TECHNICAL  
DATA  
SHEET



**BRISTAN**

D5